

У П Р А Ж Н Е Н И Е №3

Изследване на маломощни захранващи блокове

В това упражнение се разучават схеми за захранване от мрежата 230V/50Hz на консуматори с малка мощност ($<10W$) без мрежов трансформатор.

Захранването от мрежата без мрежов трансформатор става, като се използва реактивното съпротивление на кондензатор. Голямата разлика между напрежението на мрежата и това което трябва да се получи (230V/AC \rightarrow 5-10V/DC) остава върху кондензатора, който определя тока във веригата (съпротивлението $X_c=1/\omega C$). След избор на конкретна схема изчисленията се свеждат до изчисление на капацитета на кондензатора. Като помощен материал да се ползват [91008b.pdf](#) и [00954a.pdf](#).

Част от работата по това лабораторно упражнение включва разучаването на готов адаптер за зареждане на батерии (за GSM апарати). Прави впечатление много широкият обхват на мрежово напрежение – 100-250V, 50/60Hz. Познанията на студентите са достатъчни за да “разгадаят” схемата и принципа на работа на адаптера.

Освен това, може да се разучат схемите MC34063 и LM2574 които се използват за захранвания с малка мощност. С подобно предназначение са и схемите ST662, UC3842 както и готовите DC/DC модули AM1/2L..., DCH01. Данните за тях са дадени съответно в [st662.pdf](#), [mc34063.pdf](#), [lm2574.pdf](#), [uc3842.pdf](#) и [am_1.pdf](#), [dch01.pdf](#).

Материали по темата на упражнението могат да се намерят в архива [Upr3.zip](#) на сайта на дисциплината.

Задачи:

1. Да се разучи принципът на работа на захранващо устройство, което работи директно от мрежата (фиг. 1) и е описано в [91008b.pdf](#). Да се изведе формула за зависимостта между капацитета на кондензатора и консумирания ток за захранваща мрежа 230V/50Hz ([91008b.pdf](#) разглежда мрежа 115V/60Hz).

2. Да се оразмери схемата от фиг. 2 с помощта на формулата от т.1 за следните параметри:

- двуполярно напрежение $\pm(4-5,5 V)$;
- ток (консумация) 15 mA;
- пулсации $< 200 mV$.

При определяне на пулсациите в изхода да се използва зависимостта на напрежението на кондензатор като функция на тока, времето и капацитета му. Да се “експериментира” схемата от фиг. 2 като се снемат основните и характеристики с помощта на LTSPICE. Да се определи ударният ток при включване – ключови думи: **Inrush current, input surge current, switch-on surge**.

3. Опитно да се снемат двата варианта на схемата от лабораторния макет. Да се измерят стойностите на изходното напрежение и да се обяснят разликите.

4. С помощта на LTSPICE да се изследват схемите от фиг. 3 и се обяснят евентуалните различия. Да се установи максималната стойност на изходния ток.

5. Да се “експериментира” с помощта на LTSPICE схемата от фиг. 3б като диодите се заменят с мостов изправител (схема Грец). Да се снимат основните характеристики и се сравнят с тези на схемата от фиг. 3б.

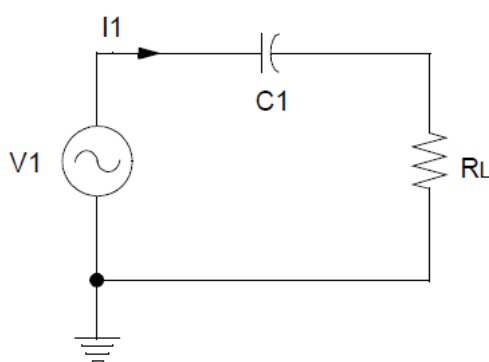

Фиг. 1

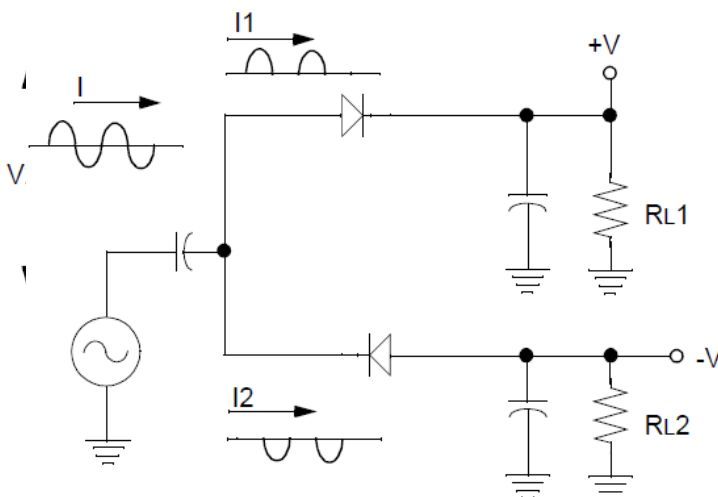

Фиг. 2

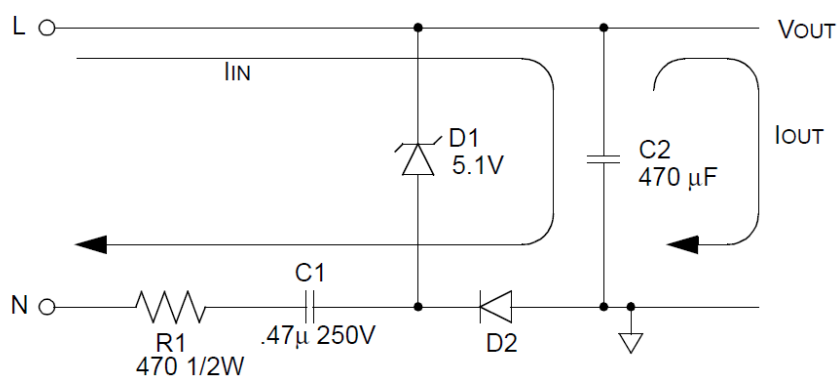

Фиг. 3а

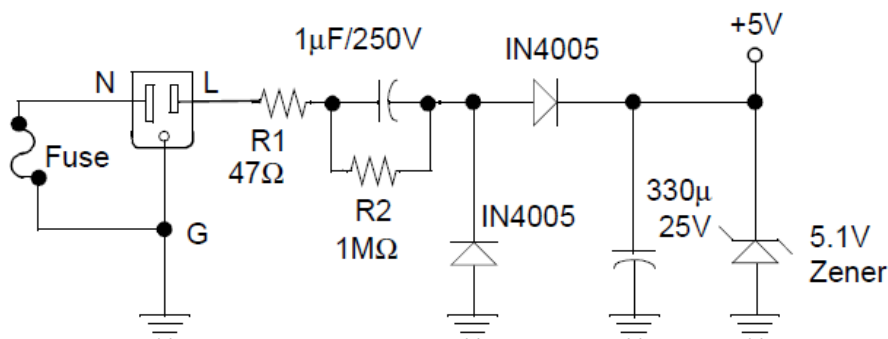

Фиг. 3б

Transformerless Power Supply

Author: Stan D'Souza
Microchip Technology Inc.

INTRODUCTION

In most non-battery applications, the power to the microcontroller is normally supplied using a wall mounted transformer, which is then rectified, filtered and regulated. In most applications, this method of generating the regulated voltage is cost effective and can be justified. However, there are applications where the PIC12/16/17 is the main controller and low voltage is not required by other components except the PIC12/16/17. In these instances, the cost of the transformer becomes the sizable cost factor in the system. Transformerless power supplies, thus, have a distinct advantage in cost as well as in size. The disadvantages of using a transformerless power supply are: (1) low current supply and (2) no isolation from the AC line voltage. The PIC12/16/17 microcontrollers draw a maximum of 10 mA, even at the highest frequency and voltage of operation, therefore low current availability is not an issue. AC line voltage isolation can be addressed by using MOVs or transient suppressors on the PIC12/16/17.

IMPLEMENTATION

When a capacitor and resistor are connected in series to an AC source, as in Figure 1, a constant current can be maintained through the resistor, so long as the reactance of the capacitors is much greater than the resistance. The current flow is dependent upon the value of the capacitor, and assuming that V_1 is much greater than V_2 , the value of the current can be assumed to be:

$$I_{RMS} = V_1/X_C \text{ where } X_C \text{ is the reactance of the capacitor.}$$

FIGURE 1:

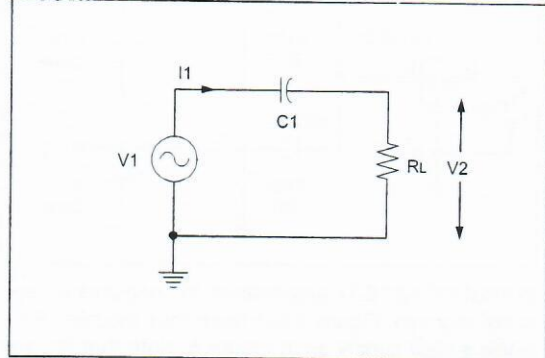

Assuming a line voltage of $V_1 = 115V$ and line frequency = 60 Hz,

$$I_{RMS} = 115(2\pi 60C) = 4300C \text{ or } I_{RMS} \approx 40 \text{ mA}/\mu\text{F}.$$

In order to get a DC voltage using this system, a pair of rectifiers and filter caps can be added as shown in Figure 2. This would give us a capability of driving one half of the current through the positive part and the other half through the negative part. The max current on each side would be = 20 mA/ μ F.

FIGURE 2:

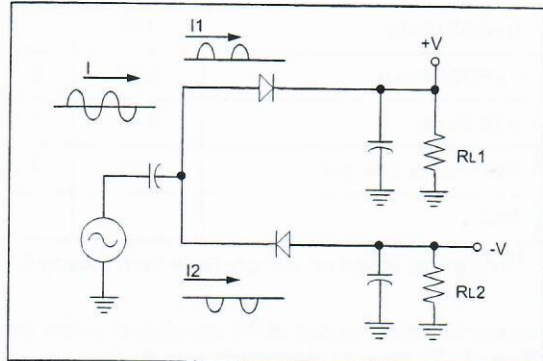

TB008

In most applications, the output voltage should be regulated. Figure 3 shows a diagram for a practical circuit where a +/- 5V regulated output is generated. Note that the neutral is connected to ground through a fuse. This would guard against improper AC wiring.

FIGURE 3:

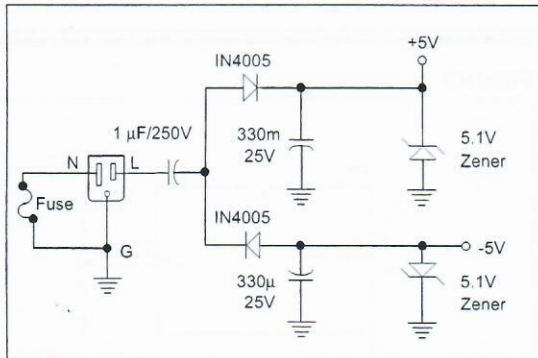

In most PIC12/16/17 applications, the negative voltage is not required. Figure 3 has been thus modified for a single ended supply as in Figure 4. Note that R1 and R2 are required for UL approval.

FIGURE 4:

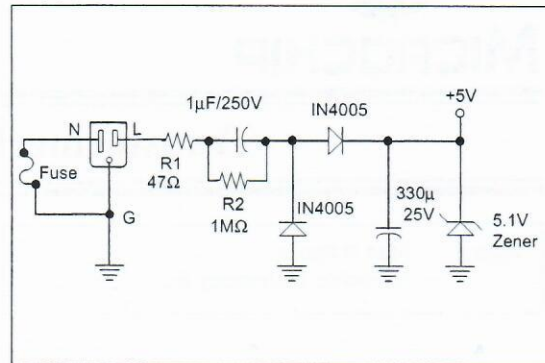

Precautions:

1. As mentioned earlier, the neutral should be connected to earth ground through a fuse. This would insure protection in case of improper wiring.
2. The AC coupling capacitors and rectifier diodes should be able to withstand the peak voltage in the system. Remember $V_{RMS} = V_{PG}/2$, where $V_{PG} = V_{PEAK}$ to earth ground voltage. Hence for a 120V system, the max voltage = 170V. For a 240V system, the max voltage = 340V.

TABLE 1: COST ANALYSIS OF A +5V POWER SUPPLY WITH/WITHOUT A TRANSFORMER:

| Components | Unit Price ⁽¹⁾ | Qty | Transformer P.S. | Qty. | Transformerless P.S. |
|-----------------------|---------------------------|-----|------------------|------|----------------------|
| 1.1 VA transformer | 5.65 | 1 | 5.65 | 0 | - |
| 1N4005 diode | 0.05 | 2 | 0.10 | 2 | 0.10 |
| 1 µF/250V cap | 0.57 | 0 | - | 1 | 0.57 |
| 5.1V Zener | 0.11 | 1 | 0.11 | 1 | 0.11 |
| 330 µF/25V filter cap | 0.17 | 1 | 0.17 | 1 | 0.17 |
| Total | | | 6.03 | | 0.95 |

⁽¹⁾ All prices based on 100 qty. price from Digikey Catalog.

As can be seen, the cost of the transformer power supply is 6 times that of the transformerless power supply. In quantities of 100, the cost of a transformerless power supply is less than a dollar.

CONCLUSION

A transformerless power supply is a low cost, small footprint alternative by which a PIC12/16/17 can be powered.



MICROCHIP

AN954

Transformerless Power Supplies: Resistive and Capacitive

*Author: Reston Condit
Microchip Technology Inc.*

INTRODUCTION

There are several ways to convert an AC voltage at a wall receptacle into the DC voltage required by a microcontroller. Traditionally, this has been done with a transformer and rectifier circuit. There are also switching power supply solutions, however, in applications that involve providing a DC voltage to only the microcontroller and a few other low-current devices, transformer-based or switcher-based power supplies may not be cost effective. The reason is that the transformers in transformer-based solutions, and the inductor/MOSFET/controller in switch-based solutions, are expensive and take up a considerable amount of space. This is especially true in the appliance market, where the cost and size of the components surrounding the power supply may be significantly less than the cost of the power supply alone.

Transformerless power supplies provide a low-cost alternative to transformer-based and switcher-based power supplies. The two basic types of transformerless power supplies are resistive and capacitive. This application note will discuss both with a focus on the following:

1. A circuit analysis of the supply.
2. The advantages and disadvantages of each power supply.
3. Additional considerations including safety requirements and trade-offs associated with half-bridge versus full-bridge rectification.

Warning: *An electrocution hazard exists during experimentation with transformerless circuits that interface to wall power. There is no transformer for power-line isolation in the following circuits, so the user must be very careful and assess the risks from line-transients in the user's application. An isolation transformer should be used when probing the following circuits.*

AN954

CAPACITIVE TRANSFORMERLESS POWER SUPPLY

A capacitive transformerless power supply is shown in Figure 1. The voltage at the load will remain constant so long as current out (I_{OUT}) is less than or equal to current in (I_{IN}). I_{IN} is limited by $R1$ and the reactance of $C1$.

Note: $R1$ limits inrush current. The value of $R1$ is chosen so that it does not dissipate too much power, yet is large enough to limit inrush current.

FIGURE 1: CAPACITIVE POWER SUPPLY

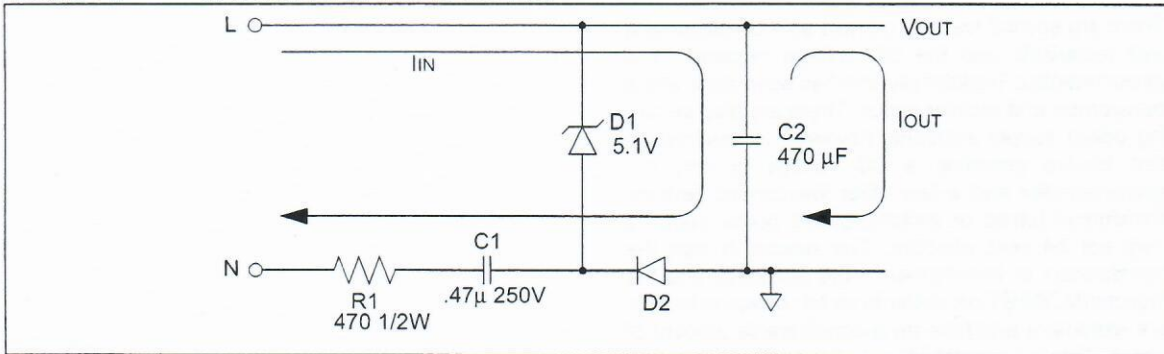

I_{IN} is given by:

EQUATION 1:

$$I_{IN} = \frac{V_{HFRMS}}{X_{C1} + R1} \geq I_{OUT}$$

Where V_{HFRMS} is the RMS voltage of a half-wave AC sine wave and X_{C1} is the reactance of $C1$.

EQUATION 2:

$$V_{HFRMS} = \frac{V_{PEAK} - V_Z}{2} = \frac{\sqrt{2}V_{RMS} - V_Z}{2}$$

Where V_{PEAK} is the peak voltage of the wall power, V_{RMS} is the rated voltage of wall power (i.e., United States: 115 VAC, Europe: 220 VAC) and V_Z is the voltage drop across $D1$.

EQUATION 3:

$$X_{C1} = \frac{1}{2\pi f C1}$$

Where f is the frequency (i.e., United States: 60 Hz, some countries: 50 Hz).

Substituting Equation 2 and Equation 3 into Equation 1 results in:

EQUATION 4:

$$I_{IN} = \frac{\sqrt{2}V_{RMS} - V_Z}{2 \left(\frac{1}{2\pi f C1} + R1 \right)}$$

The minimum value of I_{IN} should be calculated for the application, while the maximum value of I_{IN} should be calculated for the power requirements of individual components.

EXAMPLE 1: CALCULATE MINIMUM POSSIBLE I_{IN}

Assume minimum values of all components except V_Z and R_1 . Assume maximum value of V_Z and R_1 .

- $V_{RMS} = 110 \text{ VAC}$
- $V_Z = 5.1 \text{ V}$
- $f = 59.5 \text{ Hz}$
- $C = C_1 = 0.47 \mu\text{F} \times 0.8 = 0.38 \mu\text{F}$
(assuming $\pm 20\%$ capacitor)
- $R = R_1 = 470 \times 1.1 = 517$ (assuming $\pm 10\%$ resistor)
- $I_{INMIN} = 10.4 \text{ mA}$

EXAMPLE 2: CALCULATE MAXIMUM POSSIBLE I_{IN}

Assume maximum values of all components except V_Z and R_1 . Assume minimum value of V_Z and R_1 .

- $V_{RMS} = 120 \text{ VAC}$
- $V_Z = 5 \text{ V}$
- $f = 60.1 \text{ Hz}$
- $C = C_1 = 0.47 \mu\text{F} \times 1.20 = 0.56 \mu\text{F}$
(assuming $\pm 20\%$ capacitor)
- $R = R_1 = 470 \times 0.9 = 423$ (assuming $\pm 10\%$ resistor)
- $I_{INMAX} = 16.0 \text{ mA}$

V_{OUT} is given by:

EQUATION 5:

$$V_{OUT} = V_Z - V_D$$

Where V_D is the forward voltage drop across D_2 .

Assuming a 5.1V zener diode and a 0.6V drop across D_2 , the output voltage will be around 4.5V. This is well within the voltage specification for PIC[®] microcontrollers.

OBSERVATIONS

Figure 2 shows an oscilloscope plot of V_{OUT} at power-up with a 10 k Ω load on the output (between V_{OUT} and ground.) The 10 k Ω load draws only 0.45 mA. As a result, the rise time of V_{OUT} is 280 ms (as fast as possible for given I_{IN} and C_2), ripple is minimal when V_{OUT} stabilizes at the voltage calculated in Equation 5, approximately 4.5V.

FIGURE 2: V_{OUT} AT START-UP WITH 10 K Ω LOAD

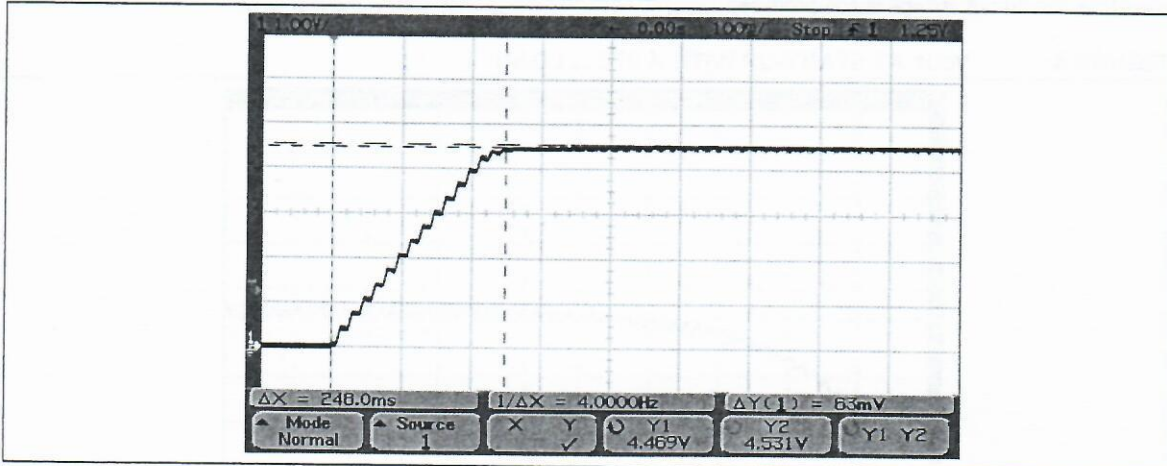

AN954

If the load is increased, the behavior of the circuit changes in several ways. Figure 3 shows an oscilloscope plot of V_{OUT} during the same time frame for a 500Ω load. A 500Ω load draws 9 mA at 4.5V. This is near the 10.4 mA limit calculated in Example 1. The rise time of V_{OUT} is longer (680 ms) as expected because not only is I_{OUT} charging C2, but a significant amount of current is being drawn by the load. V_{OUT} stabilizes at approximately 4.1V, about four tenths of a volt below the output voltage calculated in Equation 5. The ripple on V_{OUT} is more pronounced with the increased current draw.

FIGURE 3: V_{OUT} AT START-UP WITH 500Ω LOAD

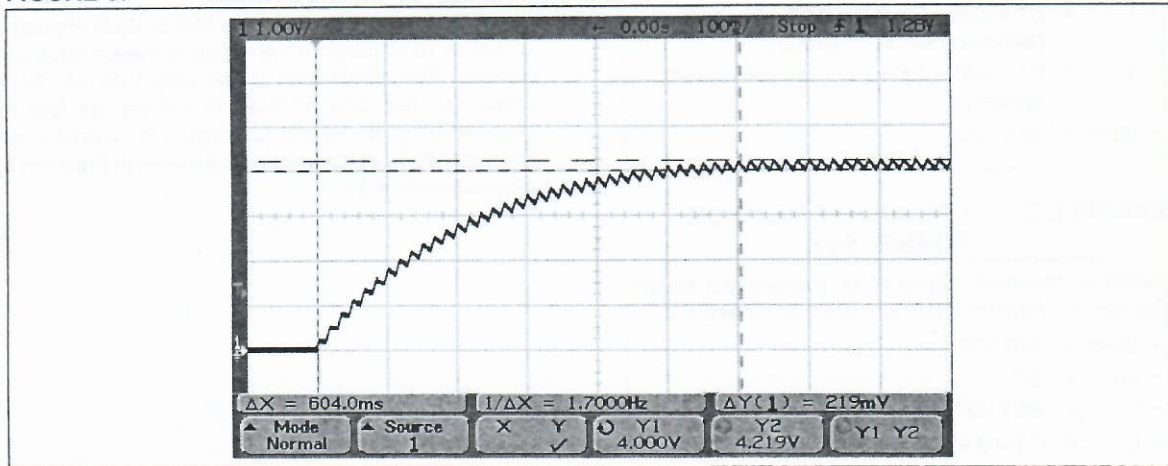

If even more current is demanded from the circuit, the supply will stabilize at a voltage below the desired level. Figure 4, shows an oscilloscope plot of V_{OUT} during the same time frame for a 270Ω load. A 270Ω load will draw approximately 16 mA with an output voltage of 4.5V. This current cannot be provided by the circuit, therefore, the output voltage is compromised.

FIGURE 4: V_{OUT} AT START-UP WITH A 270Ω LOAD

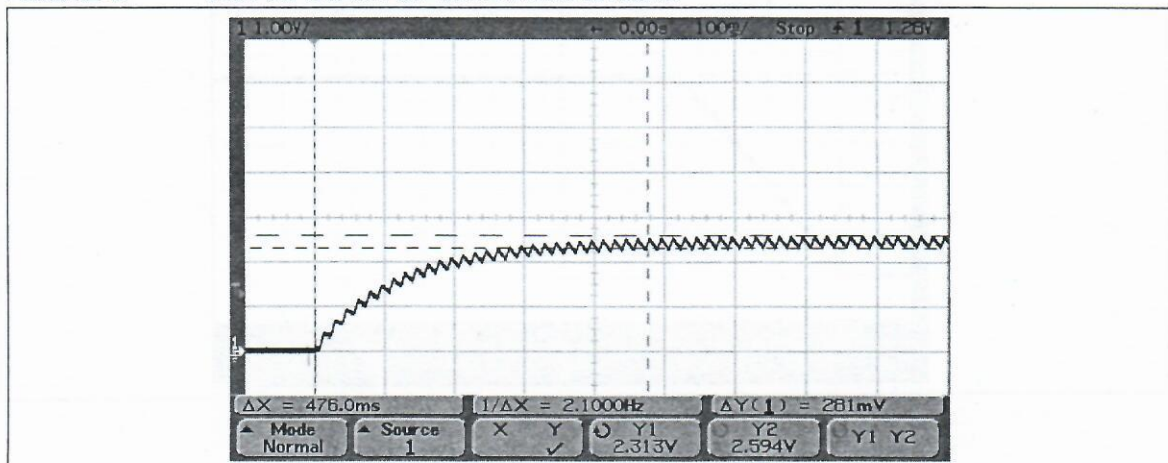

POWER CONSIDERATIONS

Determining the power dissipation of the components in the circuit is a critical consideration. As a general rule, components should be selected with power ratings at least twice the maximum power calculated for each part. For AC components, the maximum RMS values of both voltage and current are used to calculate the power requirements.

Sizing R1:

The current through R1 is the full-wave current. This current is equivalent to the line voltage divided by the impedance of C1.

EQUATION 6:

$$P_{r1} = I^2 R = (V_{RMS} * 2\pi f C)^2 R I$$

$$= (21.3 \text{ mA})^2 (470 \Omega \times 1.1) = 0.23 \text{ W}$$

(assuming $\pm 10\%$ resistor)

Doubling this gives 0.46W, so a 1/2W resistor is sufficient.

Sizing C1:

Assuming a maximum wall voltage of 120 VAC, double this is 240V. A 250V X2 class capacitor will suffice.

Note: The class of X2 capacitor is intended for use in applications defined by IEC664 installation category II. This category covers applications using line voltages from 150 to 250 AC (nominal).

Sizing D1:

D1 will be subjected to the most current if no load is present. Assuming this worst case condition, D1 will be subjected to approximately the full-wave current once C2 is charged. This current was calculated when sizing R1 (see above).

EQUATION 7:

$$P_{d1} = I x V = (21.3 \text{ mA})(5.1 \text{ V}) = 0.089 \text{ W}$$

Doubling this exceeds 1/4W, so a 1/2W 5.1V zener diode is a good choice.

Sizing D2:

The maximum RMS current that will flow through D2 was calculated in Example 2. Assuming a 0.7V drop across the resistor for half the wave, the following equation (over) approximates the power dissipated in D2.

EQUATION 8:

$$P_{d2} = I x V = (16.0 \text{ mA})(0.7 \text{ V}) = 0.011 \text{ W}$$

A 1/8 W rectifier is sufficient for D2.

Sizing C2:

C2 should be rated at twice the voltage of the zener diode. In this case, a 16V electrolytic capacitor will work. C2 simply stores current for release to the load. It is sized based on the ripple that is acceptable in VOUT. VOUT with decay according to Equation 9.

EQUATION 9:

$$V_{out} = V_d e^{-\frac{t}{RC}}$$

V_D was calculated in Equation 5

Advantages and Disadvantages

Advantages of Capacitive Power Supply:

1. Significantly smaller than a transformer-based power supply.
2. More cost effective than a transformer-based or switcher-based power supply.
3. Power supply is more efficient than a resistive transformerless power supply (discussed next).

Disadvantages of Capacitive Power Supply:

1. Not isolated from the AC line voltage which introduces safety issues.
2. Higher cost than a resistive power supply.

AN954

RESISTIVE TRANSFORMERLESS POWER SUPPLY

A basic resistive transformerless power supply is shown in Figure 5. Instead of using reactance to limit current, this power supply simply uses resistance. As with the capacitive power supply, V_{OUT} will remain stable as long as current out (I_{OUT}) is less than or equal to current in (I_{IN} .)

FIGURE 5: RESISTIVE POWER SUPPLY

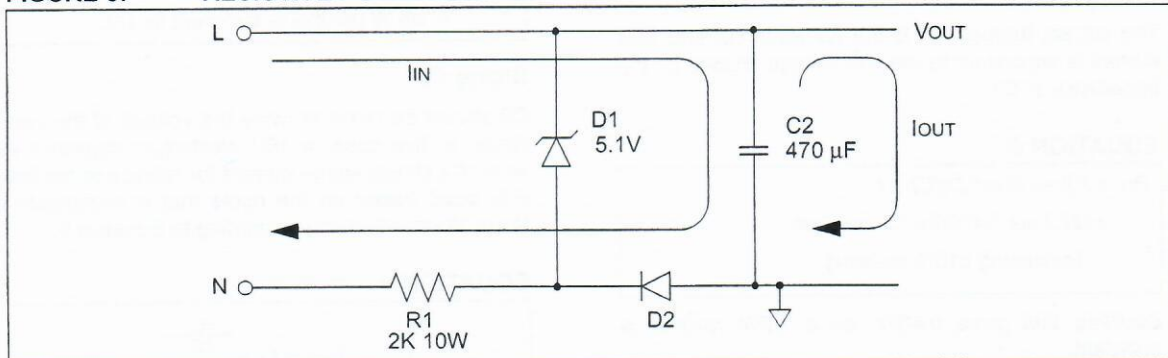

I_{IN} is given by:

EQUATION 10:

$$I_{IN} = \frac{V_{HFRMS}}{R1} \geq I_{OUT}$$

Where V_{HFRMS} is the RMS voltage of a half-wave AC sine wave.

EQUATION 11:

$$V_{HFRMS} = \frac{V_{PEAK} - V_Z}{2} = \frac{\sqrt{2}V_{RMS} - V_Z}{2}$$

Where V_{PEAK} is the peak voltage of the wall power, V_{RMS} is the rated voltage of wall power (i.e., United States: 115 VAC, Europe: 220 VAC), and V_Z is the voltage drop across D1.

Substituting Equation 11 into Equation 10 results in:

EQUATION 12:

$$I_{IN} = \frac{\sqrt{2}V_{RMS} - V_Z}{2R1}$$

The minimum value of I_{IN} should be calculated for the application while the maximum value of I_{IN} should be calculated for power requirements.

EXAMPLE 3: CALCULATE MINIMUM POSSIBLE I_{IN}

Assume minimum value of V_{RMS} . Assume maximum value of V_Z and R.

- $V_{RMS} = 110 \text{ VAC}$
- $V_Z = 5.1 \text{ V}$
- $R = R1 = 2 \text{ k}\Omega \times 1.1 = 2.2 \text{ k}\Omega$ (assuming $\pm 10\%$ resistor)

$I_{INMIN} = 34.2 \text{ mA}$

EXAMPLE 4: CALCULATE MAXIMUM POSSIBLE I_{IN}

Assume maximum value of V_{RMS} . Assume minimum value of V_Z and R.

- $V_{RMS} = 120 \text{ VAC}$
- $V_Z = 5 \text{ V}$
- $R = R1 = 2 \text{ k}\Omega \times 0.9 = 1.8 \text{ k}\Omega$ (assuming $\pm 10\%$ resistor)

$I_{INMIN} = 45.8 \text{ mA}$

V_{OUT} is the same as given for the capacitive power supply (see Equation 5).

OBSERVATIONS

The observations for the resistive power supply are very similar to the capacitive power supply. Please refer to the "Observations" in Section "Capacitive Transformerless Power Supply" for more details.

Figure 6, Figure 7 and Figure 8 show V_{OUT} at start-up for the resistive power supply with loads of $10\text{ k}\Omega$, 270Ω and 100Ω , respectively. These loads correspond to output currents of 0.45 mA , 16 mA and 45 mA , respectively, assuming an output voltage of 4.5 V . Clearly V_{OUT} is not 4.5 V in Figure 6 because the current demand placed on the power supply is too high.

FIGURE 6: V_{OUT} AT START-UP WITH $10\text{ k}\Omega$ LO AD

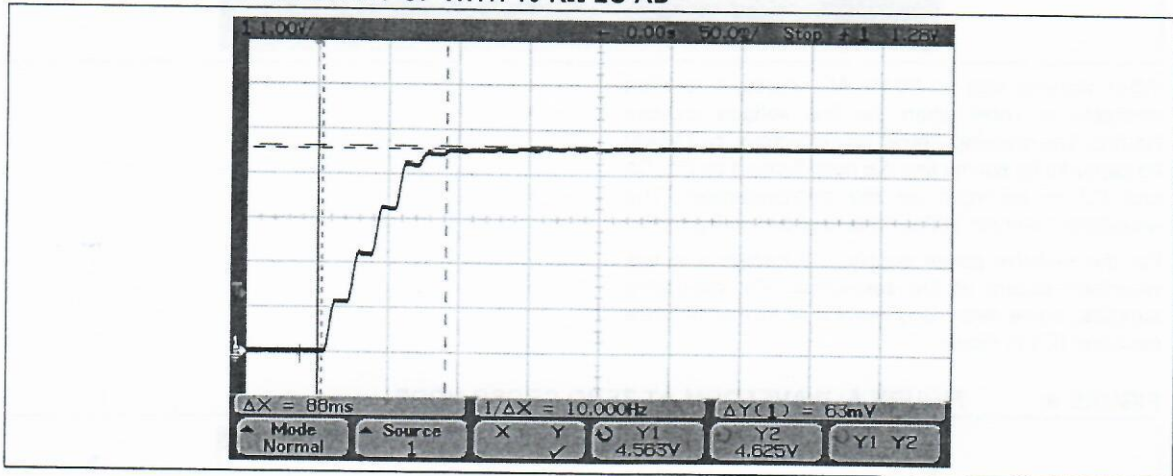
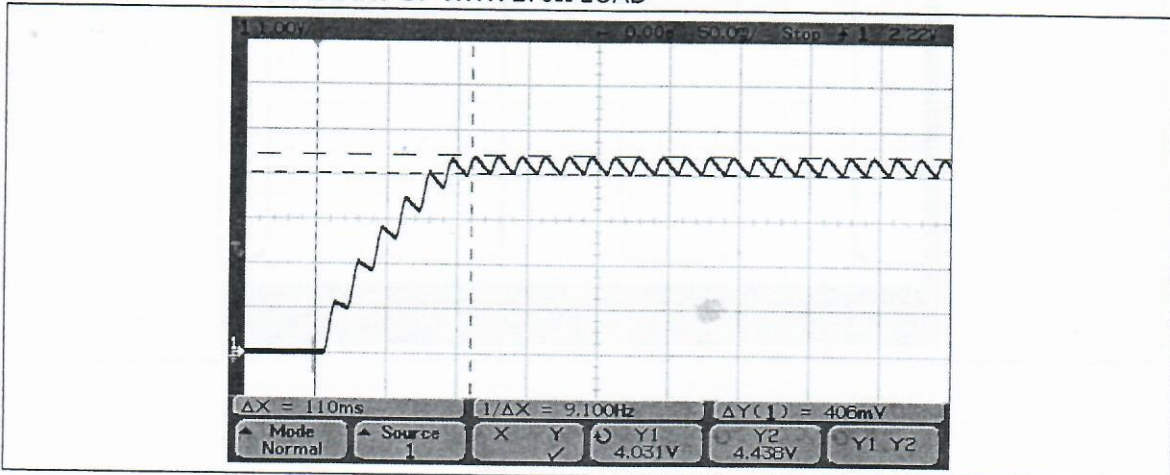
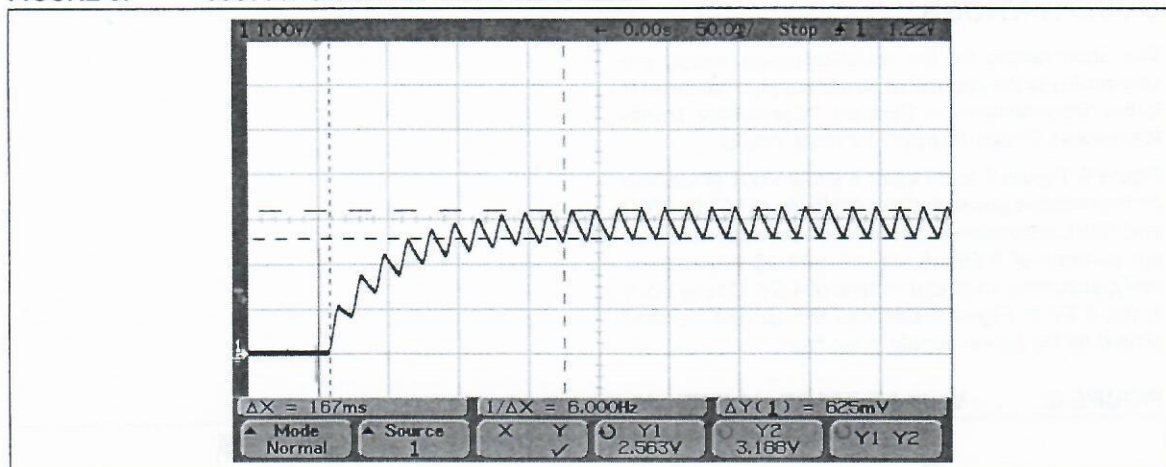

FIGURE 7: V_{OUT} AT START-UP WITH 270Ω LOAD



AN954

FIGURE 8: V_{OUT} AT START-UP WITH 100Ω LOAD



When working with an 60 Hz AC source, it is often desirable to know when the line voltage crosses Neutral. The crossing, known as zero-cross, can easily be captured by connecting the node formed by D1, C1 and D2 to an input on the microcontroller. The waveform observed at this node is shown in Figure 9.

For the resistive power supply, the transition in this waveform occurs at the zero-cross. For capacitive supplies, some delay is present due to the in-series capacitor (C1 in Figure 1).

FIGURE 9: FIGURE A: WAVEFORM AT ZERO CROSS NODE

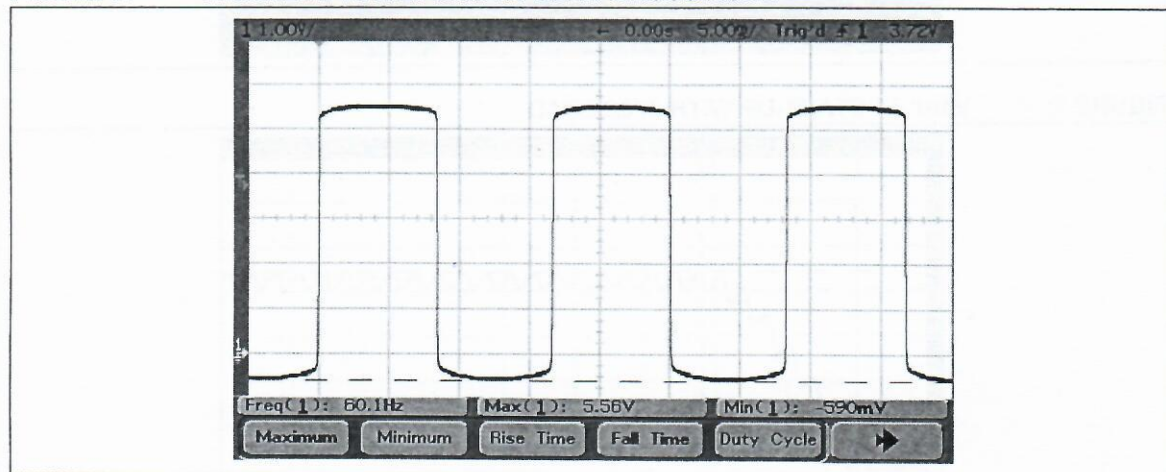

POWER CONSIDERATIONS

Selecting component power rating in the circuit is a critical consideration. As a general rule, components should be sized at twice the maximum power calculated for each device. For the AC components, the RMS values of both voltage and current are used to calculate the power requirements.

Sizing R1:

EQUATION 13:

$$P_{R1} = I^2 R = \frac{V^2}{R}$$

$$\left(\frac{120^2}{2 \text{ k}\Omega \times 0.9} \right) = 8W$$

(assuming $\pm 10\%$ resistor)

A 10W resistor builds in 2 watts of safety so it will be used.

Sizing D1:

With no load, the current through D1 will be approximately equal to the full wave current through R1.

EQUATION 14:

$$P_{D1} = V_{xI} = V_z \frac{V_{RMS}}{R I}$$

$$5.1V \left(\frac{120}{2 \text{ k}\Omega \times 0.9} \right) = 0.34W$$

A 1 W 5.1V zener diode should be used.

Sizing D2:

The maximum RMS current that will flow through D2 was calculated in Example 4. Assuming a 0.7V drop across the resistor for half the wave, the following equation (over) approximates the power dissipated in D2.

EQUATION 15:

$$P_{D2} = I_x V = (45.8 \text{ mA})(0.7V) = 0.032W$$

A 1/8W diode is a sufficient for D2.

Sizing C2:

C2 should be rated at twice the voltage of the zener diode. In this case, a 16V electrolytic capacitor will work. C2 simply stores current for release to the load. It is sized based on the voltage fluctuations that are acceptable on VOUT. VOUT decays according to Equation 9.

Advantages and Disadvantages

Advantages of Resistive Power Supply:

1. Significantly smaller than a transformer-based power supply.
2. Lower cost than a transformer-based power supply.
3. Lower cost than a capacitive power supply.

Disadvantages of Resistive Power Supply:

1. Not isolated from the AC line voltage which introduces safety issues.
2. Power supply is less energy efficient than a capacitive power supply.
3. Loss energy is dissipated as heat in R1.

AN954

OTHER CONSIDERATIONS

Safety Considerations

Disclaimer: This section does not provide all the information needed to meet UL requirements. UL requirements are application specific and are not exclusive to the circuit design itself. Some of the other characteristics that are factors in meeting UL requirements are trace width, trace proximity to one another, and (but not limited to) other layout requirements. Visit the Underwriters Laboratories Inc. Web page at www.ul.com for more information.

FIGURE 10: CAPACITIVE POWER SUPPLY WITH SAFETY CONSIDERATIONS

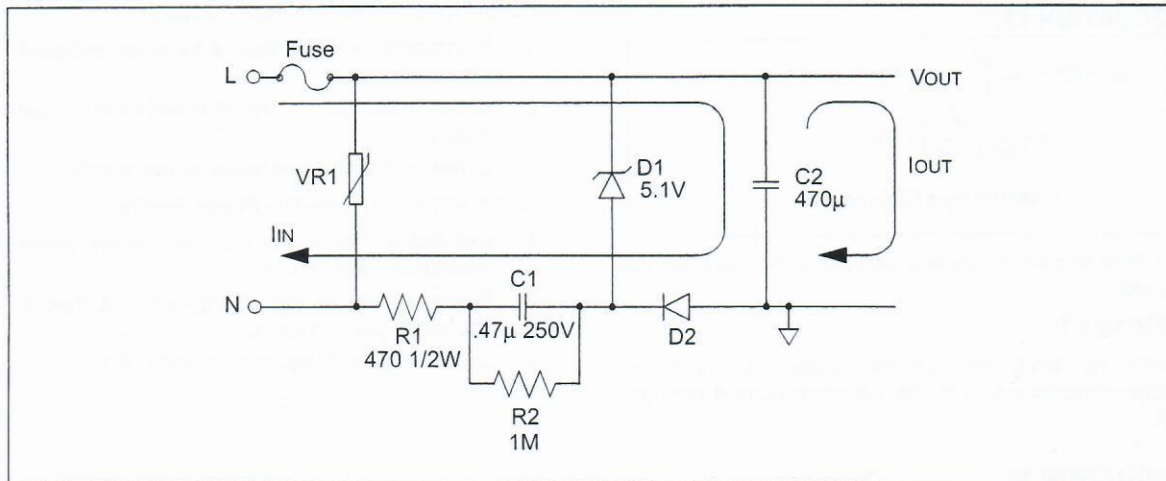
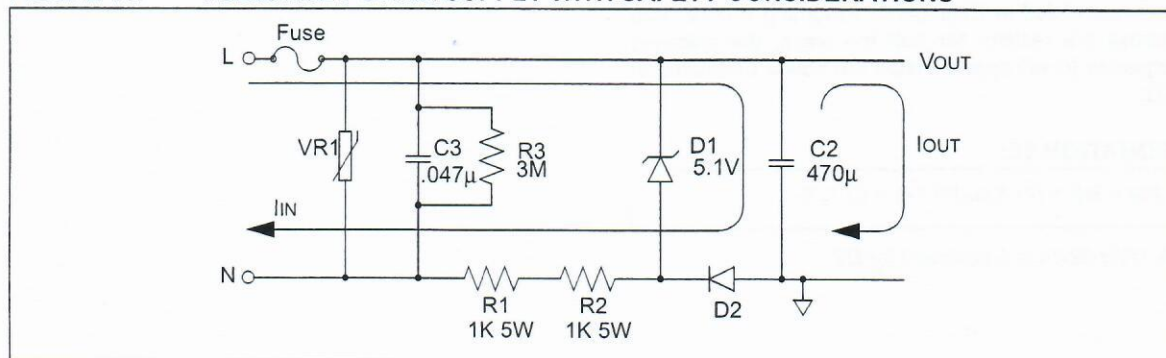

Figure 10 shows a capacitive power supply with several UL considerations designed in. A fuse is added to protect the circuit during an over-current condition. Adding R2 in parallel with C1 creates a filter that will attenuate EMI from traveling back onto the line. A varistor, or MOV, provides transient protection.

Figure 11 shows a resistive power supply with several UL considerations⁽¹⁾ designed in.

Note 1: User must research applicable UL specifications that apply to the user's specific product. Products must be tested by a certified lab to make sure all UL requirements are met.

FIGURE 11: RESISTIVE POWER SUPPLY WITH SAFETY CONSIDERATIONS



As with the capacitive power supply, a fuse and varistor have been added to provide over current and transient protection respectively. The 2 kΩ resistor is separated into two 1 kΩ in-series resistors. Series resistors should be split into two resistors so that a high voltage transient will not bypass the resistor. The use of the two resistors also lowers the potential across the resistors, reducing the possibility of arcing. C3 and R3 create a filter which prevents EMI created by the circuit from migrating onto the Line or Neutral busses.

FIGURE 12: RESISTIVE POWER SUPPLY WITH BRIDGE RECTIFIER

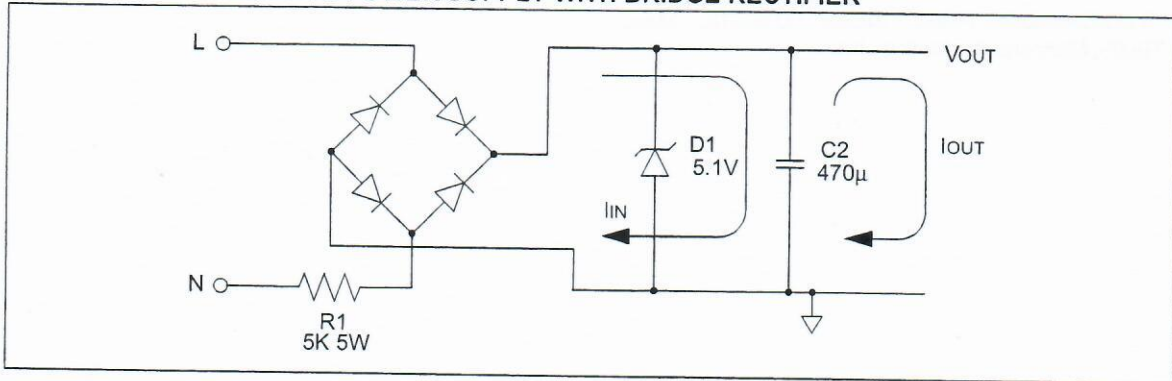

Bridge Rectification

The current output of each of the circuits described can be increased by 141% with the addition of a low-cost bridge rectifier. Figure 12 shows what the resistive power supply looks like with this addition.

Instead of providing current during only one half of the AC waveform period, current is supplied by the source during both halves. Equation 16 gives the RMS voltage for the full wave RMS voltage seen across R1.

EQUATION 16:

$$V_{FLRMS} = \frac{\sqrt{2}V_{RMS} - V_Z}{\sqrt{2}}$$

Substituting into Equation 10 gives an equation for IIN:

EQUATION 17:

$$I_{IN} = \frac{\sqrt{2}V_{RMS} - V_Z}{\sqrt{2}R}$$

Advantages of bridge rectifier over half-wave rectifier:

1. Provides 141% more current.
2. More efficient.
3. VOUT is more stable.

Disadvantages of bridge rectifier compared to half-wave rectifier:

1. More expensive.
2. VOUT is not referenced to just line or neutral making triac control impossible.

AN954

CONCLUSION

Transformerless power supplies are instrumental in keeping costs low in microcontroller-based applications powered from a wall receptacle. Both resistive and capacitive power supplies offer substantial cost and space savings over transformer-based and switch-based supplies. Capacitive power supplies offer an energy efficient solution, while resistive power supplies offer increased cost savings.

REFERENCES

"*Transformerless Power Supply*" D'Souza, Stan, TB008, Microchip Technology Inc.